

FUHO AV to VGA high resolution Video converter

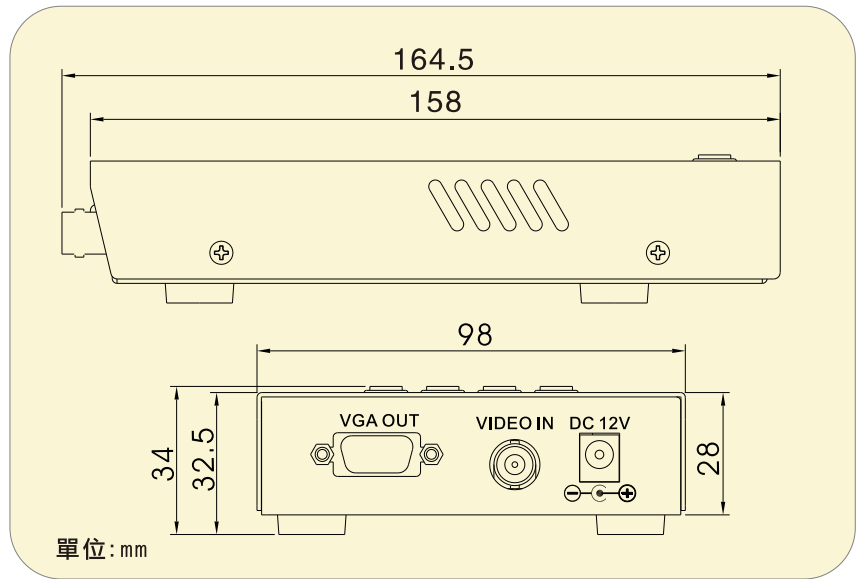

FUM-T9

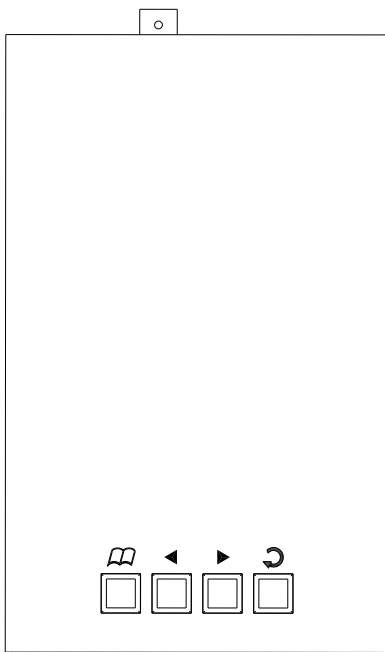

Feature:

- 1.SXGA (1280*1024) super high resolution, Sequential scanning flicker less.
- 2.LCD/CRT/Projector/plasma monitor support.
- 3.Play & Play free form driver and OS installation.
- 4.NTSC & PAL available.
- 5.Adjustable on contrast, brightness and saturation.
- 6.Keypad control panel.
- 7.OSD indicator.

Specification

Video input	Format	EIA/ NTSC: 525 Lines /60Hz , CCIR/PAL :625 Lines /50 Hz
	Signal	Composite Video 1Vp-p (75ohm)
Video output	Signal	VGA~ SXGA, maximum resolution 1280 x 1024 (SXGA)
Connect ports	Input	BNC connector.
	Output	D-SUB VGA port.
Power	Rated power	100V~ 240V /50~60 Hz / DC12V 1A.
	Power consumption	DC12V 800Ma.
User interface	Control port	Keypad panel. OSD indicator.
	Menu language	Illustration and English.
Display	Resolution	VGA 640x480 ~ SXGA 1280 x 1024 adjustable on menu.
	Brightness adjustment	Menu adjustment.
	Contrast adjustment	Menu adjustment.
	Horizon adjustment	Menu adjustment.
	Vertical adjustment	Menu adjustment.
Weight	0.5 kg	
Size	3.5 cm (H) x 16 cm (L) x 9.5 cm (W)	